



M8460Se 203 dpi



Wide Web Print Engine | M84Se Series



The "Standard" for all Automatic Print and Apply Labeling

Streamlined Features

- 6" Wide Web Print Engine
- Industry-Leading Throughput
- High-Duty Cycle Applicator
- Rugged Industrial Design
- Plug-In Interface Modules
- Standard Real-Time Clock
- Fast and Easy Changeovers
- Standard Bi-Directional Communication

Industry Verticals

- Aerospace
- Automotive
- Distribution
- Manufacturing
- Logistics
- Government
- Healthcare
- Transportation
- Pharmaceutical

Industry Applications

- Compliance Labeling
- Warehouse Logistics
- Pallet Tracking
- Retail Labeling
- Product Authentication
- Cross-Docking
- Shipping Labels





GENERAL SPECIFICATIONS

M8460Se

MODEL		M8460Se
PRINTING SPECIFICATIONS		
Print Method		Direct Thermal/Thermal Transfer
Print Resolution		203 dpi (8 dots/mm)
Maximum Print Speed		8 ips (250 mm/s)
Maximum Print Area		6" (152 mm) W x 49.2" (1249 mm) L
MEDIA SPECIFICATIONS		
Sensor Type		Transmissive sensor for die cut labels & tags. Reflective sensor for use with preprinted sensing marks. Automatic, programmable setting of top form.
Media Type		Die cut labels, plain paper face-stock and synthetics. Maximum unwind torque: 8 ft./lbs
Back Feed		Adjustable, ± 10" (255 mm)
Media Size	Width	2" (53 mm) to 6.5" (165 mm)
	Length	Minimum 0.24" (6 mm) Minimum 4" (102 mm) with RFID Tag <i>Note: Minimum label length at print speeds greater than 6 ips is 1 inch</i>
	Thickness	0.002" – 0.0106" (0.06 mm – 0.268 mm)
Ribbon		Maximum 6.5" (165 mm) W x 1968' (600 m) L / Minimum 2.1" (53 mm) W, Face In Wind
MEMORY		
Processor		32-BIT RISC
Memory		16 MB Standard RAM, 2 MB Standard Flash, Optional 1 MB PCMCIA, Optional 6 MB Flash (Total)
FONT/BARCODE SYBLOGIES		
Fonts		Bitmap - 12 proportional, mono-spaced and outline fonts (Code table 858). Internal CG Triumvirate & CG Times fonts scalable from 2 to 99 points. Optional downloaded TrueType fonts.
Barcode	Linear	UPC-A/E, EAN-8, EAN-13, Code 39, Code 93, Code 128, Codabar, MSI, Bookland, Industrial 2/5, Interleaved 2/5, Matrix 2/5, Postnet™, GS1-128, GS1-DataBar™, Intelligent Mail® Barcode (IMB)
	2-D	PDF417, Micro PDF417, Truncated PDF417, Maxicode™, Data Matrix, QR Code, Composite Symbology
COMMUNICATION INTERFACE		
Interfaces		RS232 Serial (up to 57.6k bps), IEEE1284 Parallel (ECP), 10/100BaseT/TX Ethernet (Wired), Wireless (802.11g), USB, RS422/485
External Connector		Ext. (Applicator I/F): 14-pin Amp
OPERATING CHARACTERISTICS		
Power Requirements		115V/220V (± 10%), 50/60 Hz (± 1%) - Auto-switching
Environment	Operating	41° to 104°F (5° to 40°C), 15-85% RH, non-condensing
	Storage	23° to 140°F (-5° to 60°C), Maximum 90% RH, non-condensing
Agency Certifications		CE, UL, CSA, TÜV, FCC Class A
Dimensions		9.7" (245 mm) W x 17.8" (452 mm) D x 11.8" (300 mm) H
Weight		27.5 lbs (12.5 kg)
OTHER FEATURES		
Standard Real Time Clock, Optional Opposite Hand Model, UHF RFID		

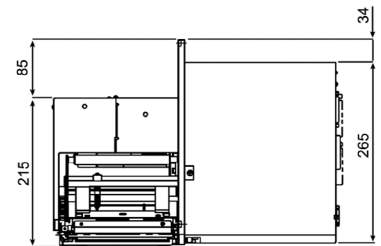
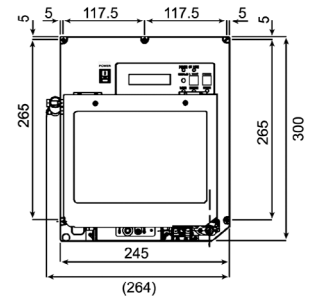
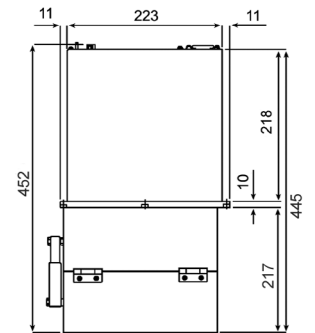

All dimensions in millimeters

SATO AMERICA, INC.

CORPORATE
10350-A Nations Ford Rd
Charlotte, NC 28273
Phone: (704) 644-1650
Fax: (704) 644-1662
satosales@satoamerica.com

LABEL MANUFACTURING, SERVICE & SALES

NORTH AMERICA	BRAZIL	ARGENTINA
Illinois	Sao Paulo	Buenos Aires
Florida		
New Jersey		
North Carolina		

©2013 SATO America, Inc. All rights Reserved. Rev E • Specifications subject to change without notice • Any unauthorized reproduction of this content, in part or whole, is strictly prohibited • SATO is a registered trademark of SATO Corporation and its subsidiaries in Japan, the U.S. and other countries. All other trademarks are the property of their respective owners.